



# 90449-F15041-7

## Adapter

### 9GHz 50Ω IP 4(F)/Stainless Plated Gold-SMA(F)/Nickel Adapter

#### Features

- High Repeatability
- Low VSWR



#### Test Report

#### Electrical Specifications

Frequency	DC-9GHz
VSWR	1.2:1(Max.)@DC-6GHz 1.3:1(Max.)@6-8GHz 1.4:1(Max.)@8-9GHz
Impedance	50Ohm
Connection 1	SMA Female
Connection 2	IP 4 Female(Receptacle)
Ref.	90449-001

#### Mechanical

Durability	SMA:500 Cycles (Min.) IP 4:5,000Cycles(Min.)
------------	-------------------------------------------------

#### Environmental

Operating Temperature	-40°C~85°C
-----------------------	------------

#### Material

Part	Material	Plated
SMA Body	Brass	Nickel
Center Pin	Phosphor Bronze	Gold
Insulator	Teflon	
IP Body	Stainless Steel	Gold

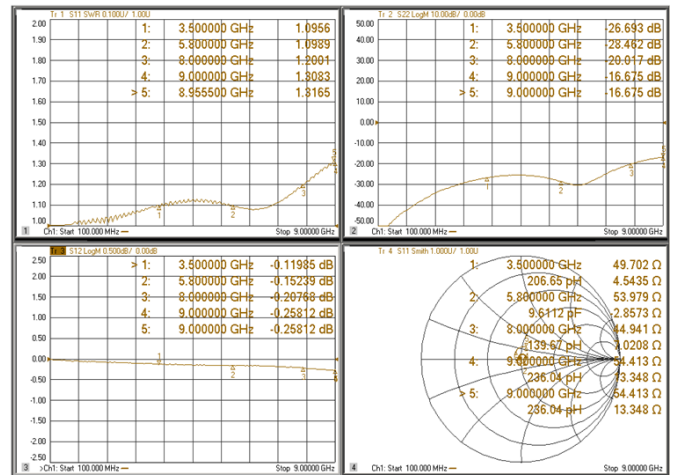

#### Note.

1. 測試數據為實驗室測試值
2. 產品使用壽命受使用環境、公差等因素所影響，實際使用壽命以客戶端測試使用狀況為主

#### Outling Drawing (Unit:mm) Tolerance:±0.1mm

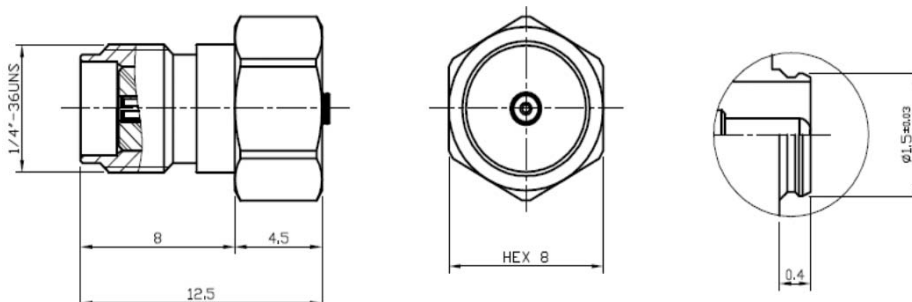

All Specification Changed Without Notification.