

Introduction

As the integration level of wireless designs becomes ever higher, the separation between RF design and integrated circuit design becomes difficult to maintain. Integrated circuits for wireless applications are appearing on the market that both simplify the RF designer's job and yet add new challenges not ordinarily considered in discrete RF circuit design. New integrated circuits offer more functions in a smaller space, but at the same time create an interfacing problem. Gone are the fifty ohm RF component building blocks, replaced by integrated circuits specified in terms of voltages and currents, some requiring differential inputs and outputs.

Balanced and Unbalanced Circuits

An unbalanced or single-ended circuit is one in which the signal is applied to one terminal of the load. The other terminal of the load is maintained at the signal's ground potential. Conversely, a balanced or differential circuit is one in which the signal is applied to one terminal of the load and a signal of equal amplitude but opposite polarity is applied to the other terminal of the load. Figure 1 shows both an unbalanced and balanced circuit.

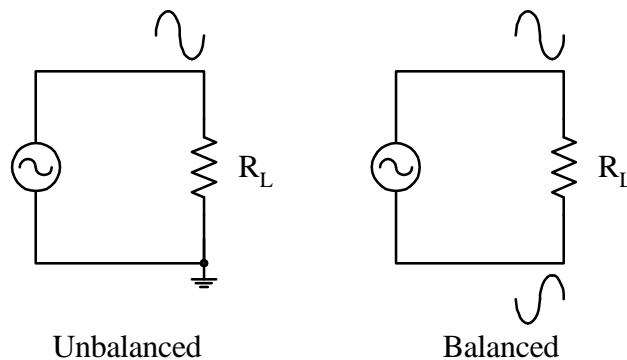

Figure 1

Each type of circuit has its particular application, but most RF work has been done with unbalanced systems and circuits. With the advent of RF integrated circuits, the differential structure is becoming increasingly prevalent. Many integrated circuit designs use the differential amplifier or Gilbert cell mixer as their primary component. These circuits are balanced structures by nature. Rather than perform the balanced to unbalanced conversion on-chip, in many cases both inputs or outputs are brought out of the integrated circuit for the RF designer to use.

Interfacing To A Balanced Circuit

Interfacing to a balanced circuit input requires that equal and opposite signals be developed from an unbalanced source. Likewise, interfacing to a balanced output requires that the two differential output lines be combined in phase to form an unbalanced output signal. Usually, when interfacing to an integrated circuit, impedance matching from the chip's input or output impedance to the RF system impedance is also required. A circuit to perform these functions simultaneously is not trivial, especially when it must be implemented with a minimum of components. Several circuits are useful for performing the balanced to unbalanced conversion task and impedance matching. By examining their topologies, a logical design process can be developed to simplify the design of *balanced* to *unbalanced* conversion circuits, or *baluns*.

As mentioned previously, a balun circuit must take an unbalanced input signal and produce two outputs of equal amplitude with a 180 degree phase difference between them. Often, it must also match impedances. Several implementations of these functions will be shown.

Transformers

A transformer may be used as a balun. By properly phasing the windings an unbalanced input can be made differential. Similarly, a balanced input can be converted to an unbalanced output. Figure 2 shows a transformer used as an output balun.

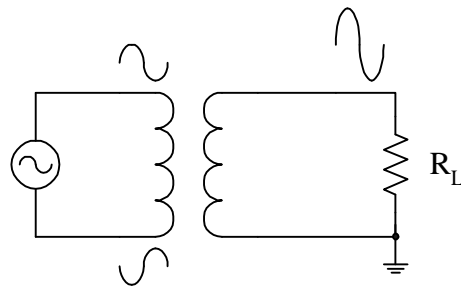

Transformer Balun

Figure 2

A transformer can also match real components of impedances. By choosing the correct turns ratio, the impedance may be stepped up or down according to system requirements. If a source with output resistance R_O is to be matched to load resistance R_L , the turns ratio is determined by

$$R_L = n^2 R_O$$

where n is the turns ratio of the transformer. Any reactive component of the output impedance would be canceled with an appropriate series or shunt reactance on either side of the transformer to complete the impedance match.

The transformer circuit has several drawbacks. First, because impedance transformation depends on the turns ratio, a custom transformer may be required. Second, the turns ratio limits the operating bandwidth and frequency of the transformer. It is difficult to achieve a large impedance transformation at high frequencies or over a large bandwidth without excessive loss. This may not be a problem in a low level stage of a transmitter, but is unacceptable in a receiver front end. Finally, the transformer may not be the optimum solution in terms of cost and size.

Three Element Discrete Balun

As an alternative to the transformer, the three element balun was developed to convert high impedance sources such as balanced mixer outputs to a single ended output. Figures 3a and 3b show the simplest implementation of a three element discrete balun.

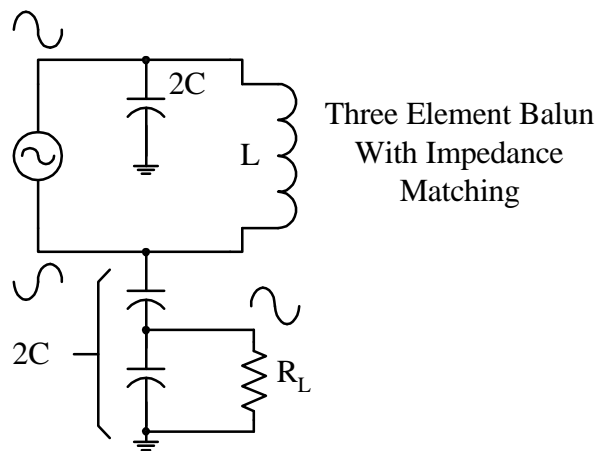
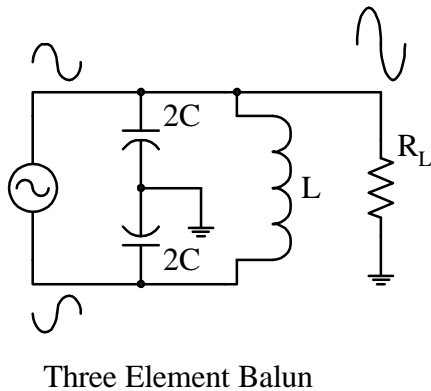
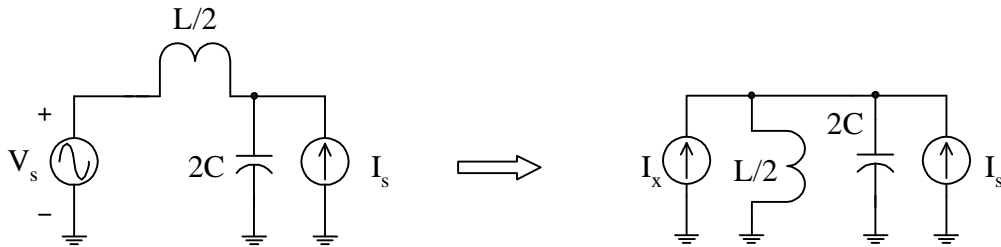
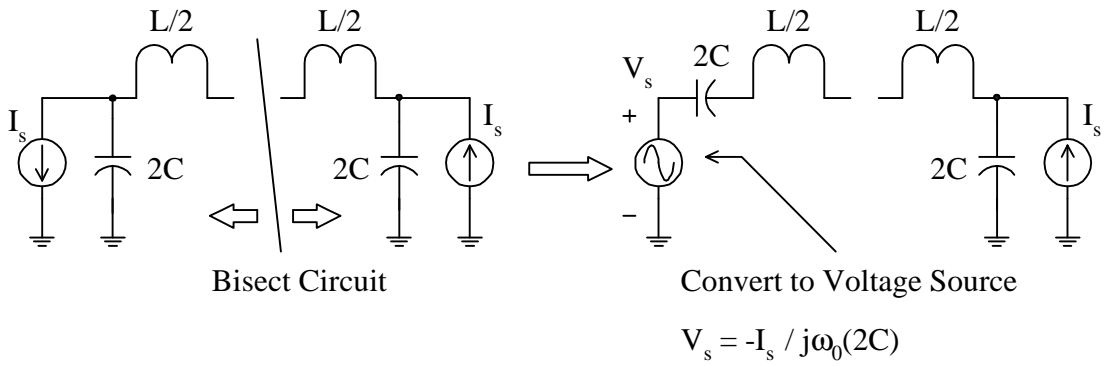
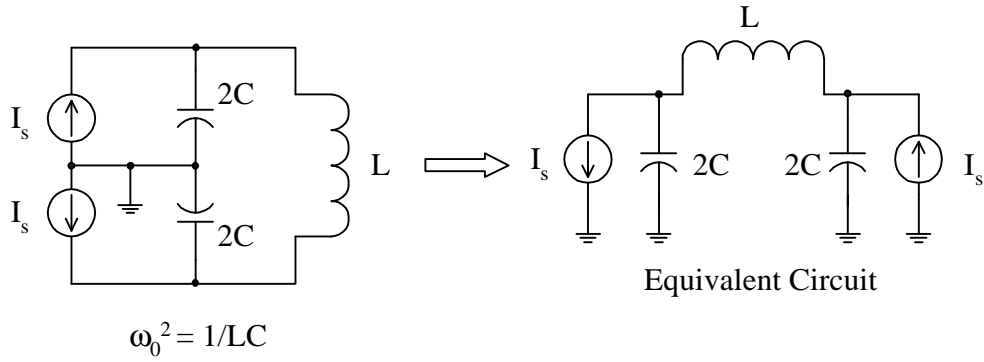

Figure 3a

Figure 3b

The operation of the balun is based on the fact that the circuit is resonant and that the reactances combine to create a 180 degree phase shift of the lower signal in Figure 3a. Currents from the differential source sum in phase at the top node of R_L producing a signal of twice the amplitude of each differential signal. Note that by itself the three element balun does not match impedances. If one of the capacitors in Figure 3 is configured as two capacitors in series as in Figure 3b, by properly choosing their ratio an impedance match can be obtained at the junction of the two capacitors. Figure 4 on the following page is a circuit analysis of how the three element balun operates.



Since $\omega_0^2 = 1/LC$, the series branch is resonant.

Convert to Current Source

$$I_x = V_s / (j\omega_0(L/2))$$

$$I_x = (-I_s / j\omega_0 2C) / (j\omega_0(L/2))$$

$$I_x = -I_s / -\omega_0^2(LC)$$

$$I_x = I_s \text{ since } \omega_0^2 = 1/LC$$

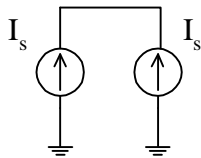

Total Current = $2 I_s$

Currents are combined in phase.

Figure 4

The three element balun shown in Figure 3 is suitable for high impedance outputs that need to be matched down to a significantly lower impedance, in other words, for high Q matches. An example would be a balanced mixer open collector output that drives a moderate impedance single-ended crystal filter. For reasons beyond the scope of this paper, as the Q of the match decreases, obtaining a simultaneous balun function and impedance match diverges until the point is reached where the three element balun circuit becomes impractical. The best approach is to simulate the proposed circuit to see if the balance/impedance match is suitable for the intended application. Also, because the match is high Q, it is important to specify tight tolerance components for the matching circuit in order to achieve high production yields.

Low And Mid Impedance Level Balun Circuits

Because most balun applications are not for high Q applications, several circuit topologies have been developed for use where the three element balun is not practical. These baluns consist of a high pass section and a low pass section connected together at the input. The unbalanced signal is applied to the input and the balanced signal is developed across the outputs by the differential phase shift characteristics of the high pass/low pass networks. Figure 5 shows the operation of the high pass/low pass balun.

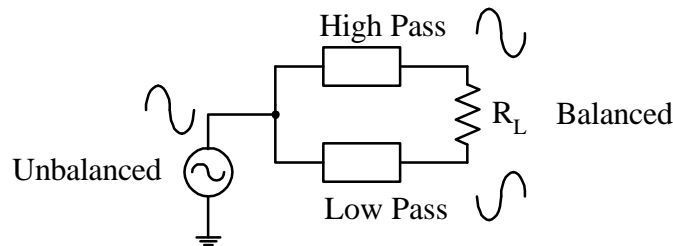

Figure 5

The high and low pass networks can be implemented with either pi or tee networks. The networks are designed to match between one-half of the balanced load impedance and twice the unbalanced source impedance. With a three element network, the designer has control over the matching network Q and the resulting phase shift through each network. When the unbalanced sides of the networks are connected in parallel, the resulting impedance seen by the unbalanced source is correct and the phase difference between the two balanced outputs is 180 degrees.

A minor variation of Figure 5 can be implemented by using L networks in a high pass/low pass configuration to simulate quarter wave transmission lines with a +90 degree phase shift on one side and a -90 degree phase shift on the other. The impedance is transformed by making the characteristic impedance of each L network equal to the geometric mean of the source and load impedances.

Measurement of Balanced Impedances at RF

In order to design a balun circuit it is necessary to characterize the source and load impedances between which the balun operates. Measuring balanced impedances at the frequencies at which wireless products operate is somewhat different from the typical measurements that the RF designer makes. For example, assume that the impedance of a mixer input needs to be determined in order to design a matching network for it.

If the mixer has an unbalanced input, the measurement may be performed with a network analyzer as a one-port impedance measurement by measuring s_{11} . The matching network can then be designed either by plotting s_{11} on the Smith chart and determining the network components graphically or by converting s_{11} to an impedance and designing the network analytically. These techniques are well-known to RF engineers.

On the other hand, if the mixer has a balanced input, the measurement must be performed as a full two-port measurement; that is, all four s-parameters must be determined. The s-parameters are then converted to z-parameters and the equivalent input circuit is determined. From the equivalent input circuit an appropriate matching network/balun may be designed. Figure 6 illustrates the difference in the measurement of impedances for single-ended and differential circuits.

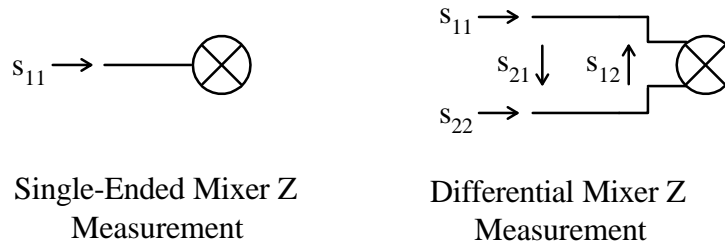

Figure 6

Extracting Equivalent Circuits From Two-Port S-Parameters

From the differential impedance measurement shown in Figure 6, an s-parameter matrix is determined. The s-parameter matrix is then converted to a z-parameter matrix as shown in Figure 7.

$$\begin{bmatrix} s_{11} & s_{12} \\ s_{21} & s_{22} \end{bmatrix} \Rightarrow \begin{bmatrix} z_{11} & z_{12} \\ z_{21} & z_{22} \end{bmatrix}$$

$$z_{11} = Z_O \left[\frac{(1 + s_{11})(1 - s_{22}) + s_{21} s_{12}}{D} \right] \quad z_{12} = Z_O \left[\frac{2 s_{12}}{D} \right]$$

$$z_{21} = Z_O \left[\frac{2 s_{21}}{D} \right] \quad z_{22} = Z_O \left[\frac{(1 - s_{11})(1 + s_{22}) + s_{21} s_{12}}{D} \right]$$

$$D = (1 - s_{11})(1 - s_{22}) - s_{21} s_{12}$$

$$D \neq 0$$

Figure 7

From two-port network theory, the equivalent impedance of the differential load can be found from the z-parameter matrix determined in Figure 7. Unlike the standard two port representation of impedance, the differential impedance, Z_{in} , is defined across ports one and two and an equation can be derived from the z-parameters and solved for Z_{in} .

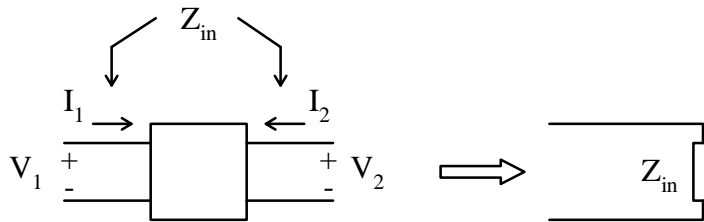

$$Z_{in} = z_{11} + z_{22} - (z_{21} + z_{12})$$

Figure 8

After the impedance Z_{in} is found, it may be bisected and the appropriate networks designed to match from the unbalanced impedance to the bisected differential impedance. For example, if the unbalanced system impedance is 50 ohms and Z_{in} is $450 + j120$ ohms, the balun would be designed according to the following parameters:

High Pass Section

Unbalanced Side Input Impedance	100 ohms
Balanced Side Output Impedance	$225 + j60$ ohms

Low Pass Section

Unbalanced Side Input Impedance	100 ohms
Balanced Side Output Impedance	$225 + j60$ ohms

Phase Difference Between Outputs

180 degrees

The unbalanced inputs connected in parallel yield the 50 ohm system impedance. The outputs in series match to the desired differential impedance.

Design Example - A Mixer With All Ports Balanced

The following design example will make use of all the material covered in the previous sections. Balun circuits will be designed using the process for each of the networks discussed in this paper. By following and understanding the methods presented, the designer will gain a basic knowledge of how to interface to balanced inputs and outputs with several different circuit topologies and when a particular topology is appropriate for a given application.

The mixer port impedances are as follows.

- RF Input Port Design Frequency = 900 MHz, $Z_O = 50$ ohms

<u>Parameter</u>	<u>Magnitude</u>	<u>Phase</u>
S_{11}	0.175	134.5 degrees
S_{21}	0.412	-10.2
S_{12}	0.417	-9.7
S_{22}	0.188	133.2

- LO Input Port Design Frequency = 1020 MHz, $Z_O = 50$ ohms

$Z_{LO} = 254$ ohms in parallel with 1.2 pf

- IF Output Port Design Frequency = 120 MHz, $Z_O = 200$ ohms

$Z_{LO} = 7500$ ohms in parallel with 1 pf

IF Port Balun/Matching Network Design

Since the IF impedance match is relatively high Q, the three element balun will be used to convert the balanced output of the mixer to a single-ended signal. A matching network will then be used to transform the impedance down to the IF impedance of 200 ohms. In the design it will be assumed that the mixer output is open collector and requires DC operating voltage to be applied to the stage through the matching network.

The initial step is to draw the equivalent output circuit along with the three element balun and select components to ensure resonance. This is done in Figure 9.

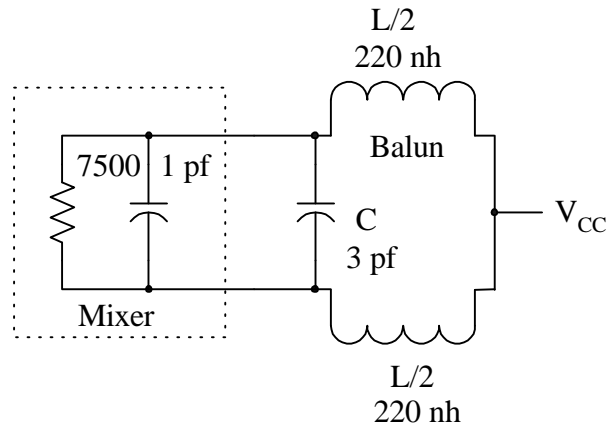
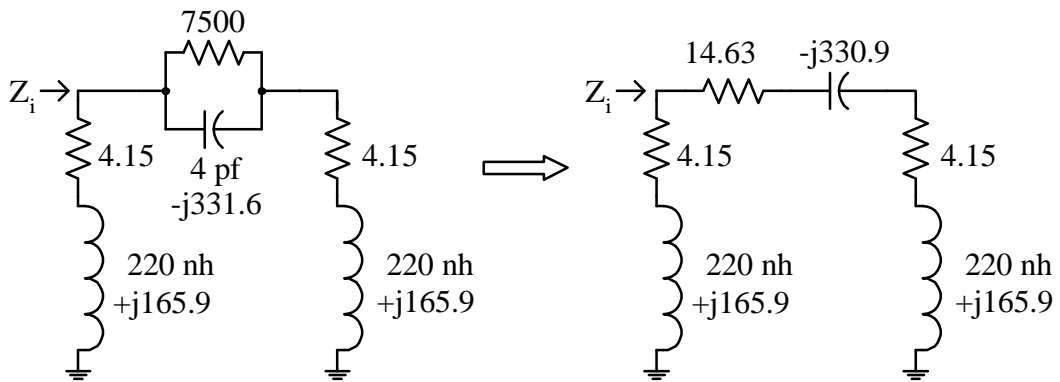

Figure 9

Note that the balun components resonate with the 1 pf mixer capacitance. If the circuit were built up in the lab, a network analyzer could be connected to either of the mixer output terminals to verify resonance. If necessary the capacitor, C, in the balun could be adjusted to bring the circuit into resonance.

After resonance is established the impedance at either of the mixer output pins is determined. In the lab a network analyzer would be used. For this paper design, an equivalent circuit is drawn and the impedance is calculated. An inductor Q of 40 has been assumed.



$$q = R_P/X_P = 7500/331.6 = 22.62$$

$$R_S = R_P(1 + q^2) = 14.63$$

$$X_S = (R_P R_S)/X_P = (7500)(14.63)/331.6$$

$$X_S = -j330.9$$

Figure 10

To simplify Figure 10, the series elements are combined to form a series RL network connected in parallel with a series RC network. Then all components are converted to a parallel network.

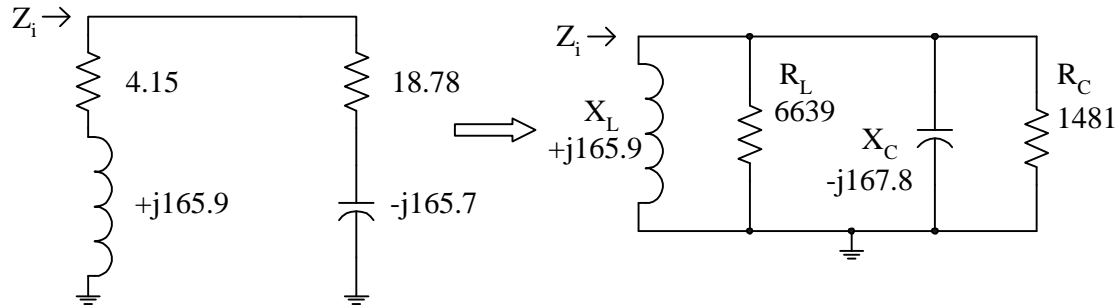

$$R_L = R_S(1 + q^2)$$

$$R_L = (4.15)(1 + 40^2)$$

$$R_L = 6639 \text{ ohms}$$

$$R_C = R_S(1 + q^2)$$

$$R_C = (18.78)(1 + (165.7/18.68)^2)$$

$$R_C = 1481 \text{ ohms}$$

$$X_L = R_S R_L / X_S$$

$$X_L = (4.15)(6639) / 165.9$$

$$X_L = +j165.9 \text{ ohms}$$

$$X_C = R_S R_C / X_S$$

$$X_C = (18.78)(1481) / 165.7$$

$$X_C = -j167.8 \text{ ohms}$$

Figure 11

Finally, the two parallel resistances, R_C and R_L are combined. Note that X_C and X_L are resonant and their combination may be treated as an infinite impedance. This is an approximation valid only with high Q circuits, but it is totally valid for this design case. Combining R_L and R_C gives the equivalent R_{eq} to which the 200 ohm filter will be matched.

$$R_{eq} = R_L // R_C$$

$$R_{eq} = 1211 \text{ ohms}$$

A three element tee network can be designed to match for 1211 ohms to 200 ohms to complete the balun/impedance matching network. For practical reasons, a high pass configuration can be used for DC blocking of the mixer operating voltage. The final balun/matching circuit is shown in Figure 12.

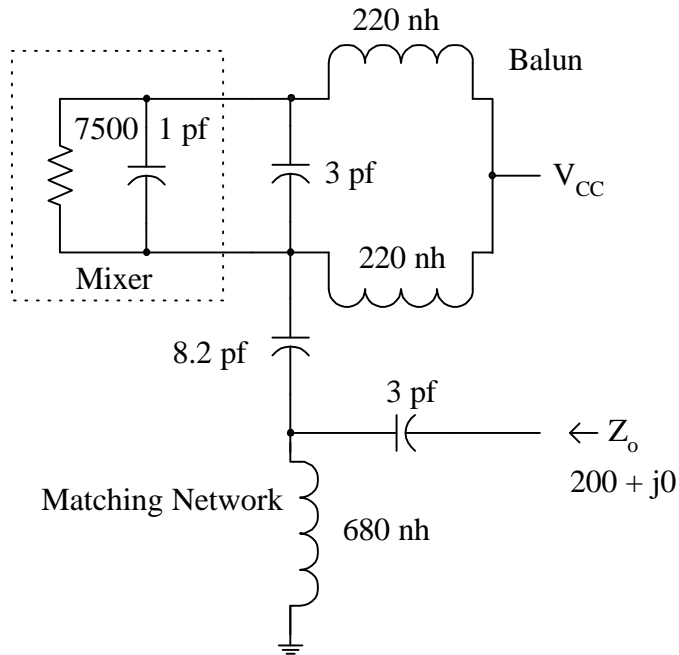

Figure 12

An equivalent circuit may be drawn to allow simulation to verify that the impedance seen at Z_o is equal to 200 ohms and that a signal applied at Z_o does produce two signals of equal amplitude and 180 degree relative phase difference at the balanced terminals. The equivalent circuit for analysis is shown below.

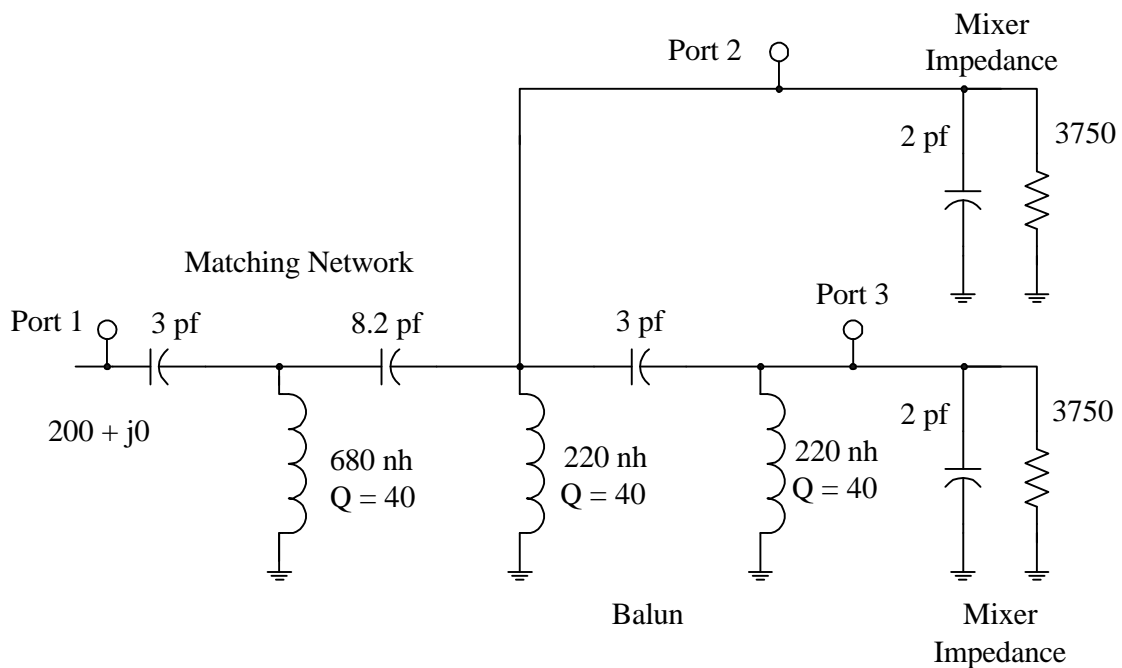
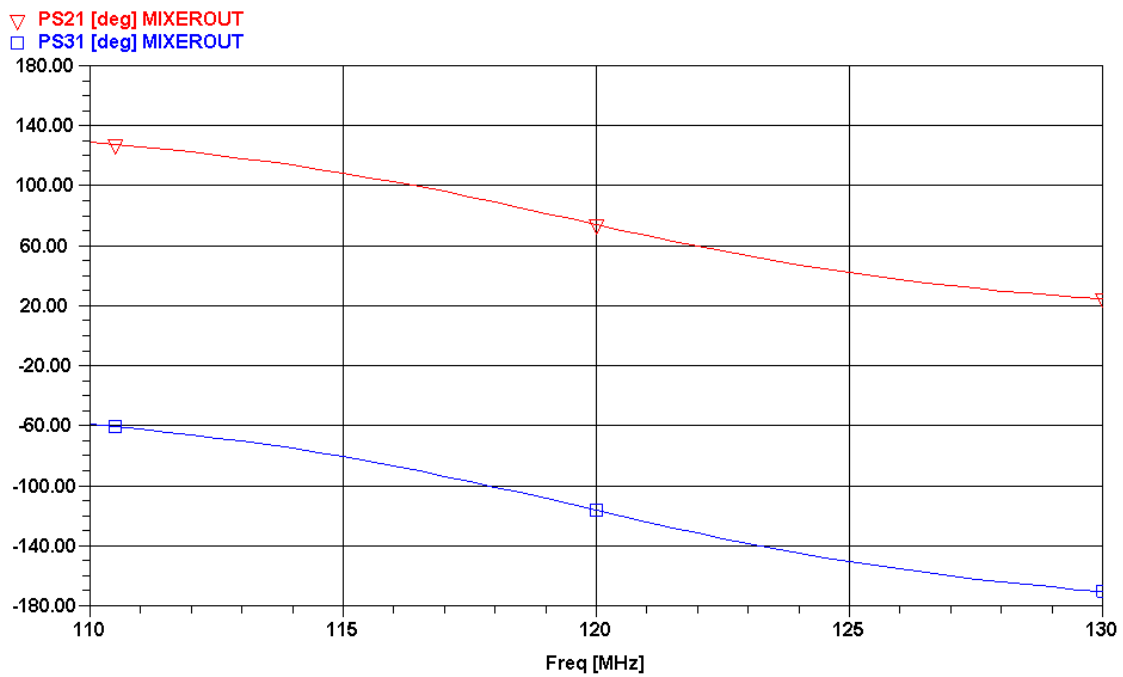
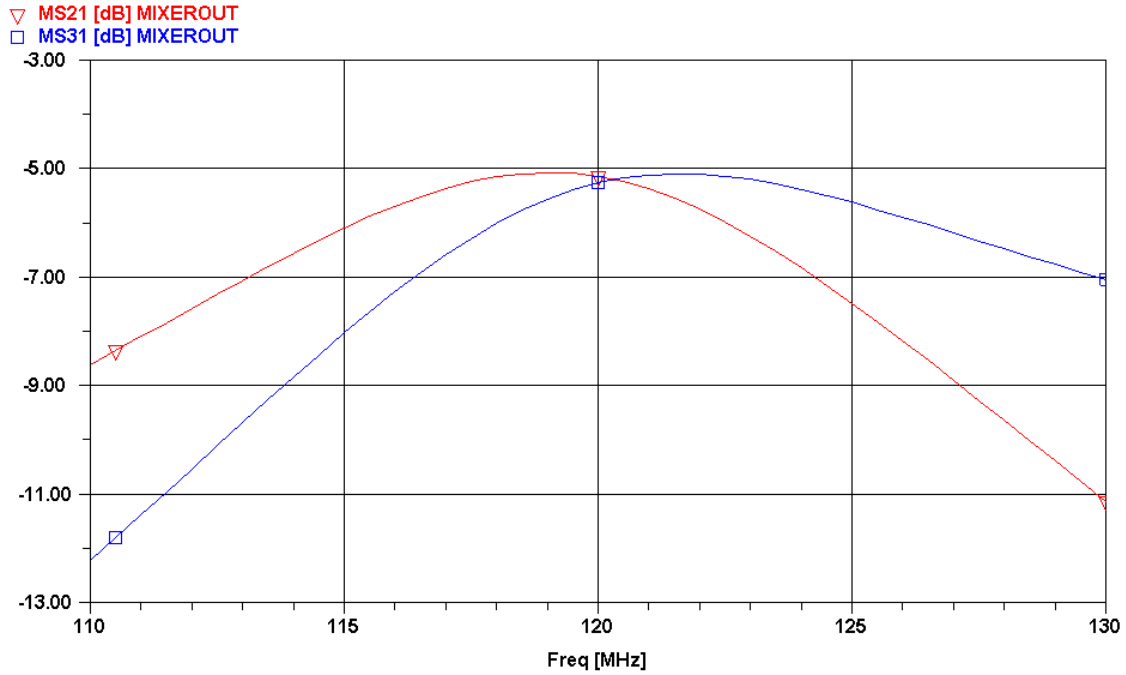

Figure 13

Note that in Figure 13 the mixer impedance has been split in two and connected to ground. Performing the analysis of the circuit, the following results are obtained.



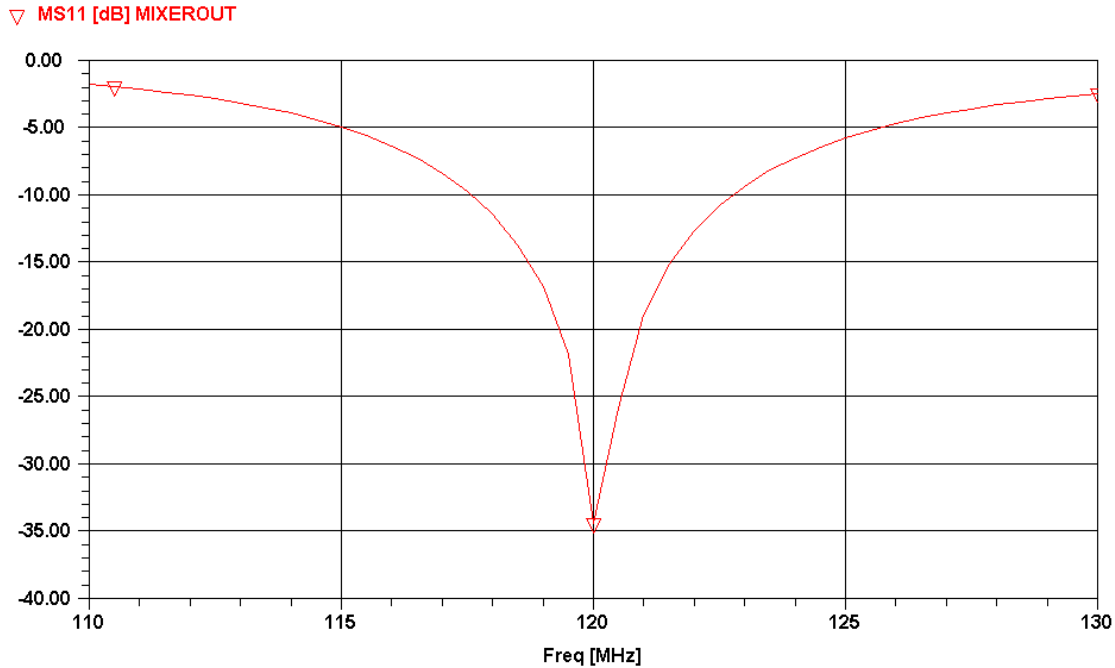

Figure 14

The first plot shows that the input signal has been split into two equal amplitude signals at the balanced port of the circuit. If lossless components had been used, each signal would be 3 dB down with respect to the input. Due to the finite Q's used in the analysis, there is an extra 2 dB of insertion loss.

The second plot shows that the phase difference between the two outputs is roughly 180 degrees. Once again, if lossless components were used the phase difference would approach 180 degrees more closely.

The third plot shows that the input port of the balun looks like 200 ohms, producing a good match to the IF filter.

LO Port Balun/Matching Network Design

The LO port impedance of 254 ohms in parallel with 1.2 pf is much lower than the IF port impedance, so the high pass/low pass balun is the best choice. First the LO impedance is bisected to produce an equivalent circuit of 127 ohms in parallel with 2.4 pf. This load impedance is then to be matched to twice the system impedance of 50 ohms, or 100 ohms at a center frequency of 1020 MHz. A pi network will be used for each side. Figure 15 shows the circuit to be designed.

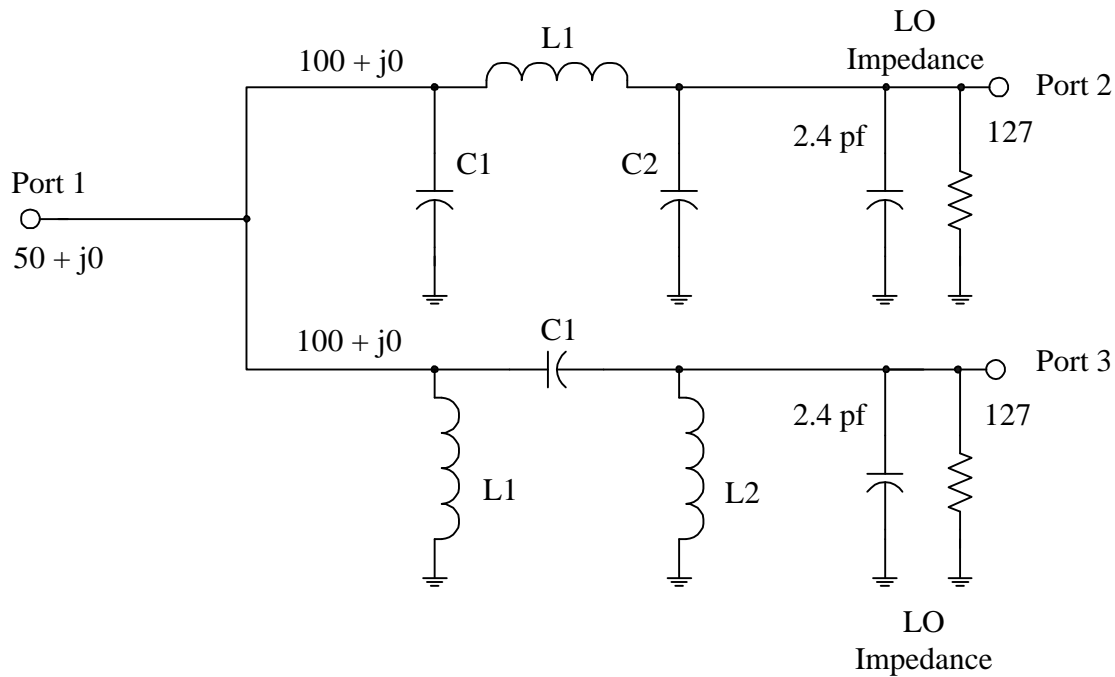

Figure 15

The design of the pi networks is relatively straightforward. In a three element matching network the designer has control over the Q of each network and the resultant phase shift versus frequency characteristic. In the design of the networks above, an initial Q is chosen, the networks are designed and then analyzed for the phase differential between ports 2 and 3. The Q is then adjusted up or down until analysis shows an impedance match and 180 degree phase differential. For the network in Figure 15, network component values are found to be as follows.

High Pass Network

L1 = 17.52 nh
 C1 = 1.38 pf
 L2 = 6.43 nh

Low Pass Network

C1 = 1.39 pf
 L1 = 17.58 nh
 C2 = 24.07 nh

Note that an inductor is required in the C2 position of the low pass matching network. The values shown above were calculated for a network Q of 1.13 which produces a differential phase shift across the output ports of 180.3 degrees. Figure 16 shows the circuit implementation with component values. Notice that L1 in the high pass network and C1 in the low pass network are not shown. When the pi network configuration is used in this manner, the two elements that are connected in parallel at the unbalanced input are parallel resonant and can be eliminated from the circuit. This results in a two component savings over the tee network.

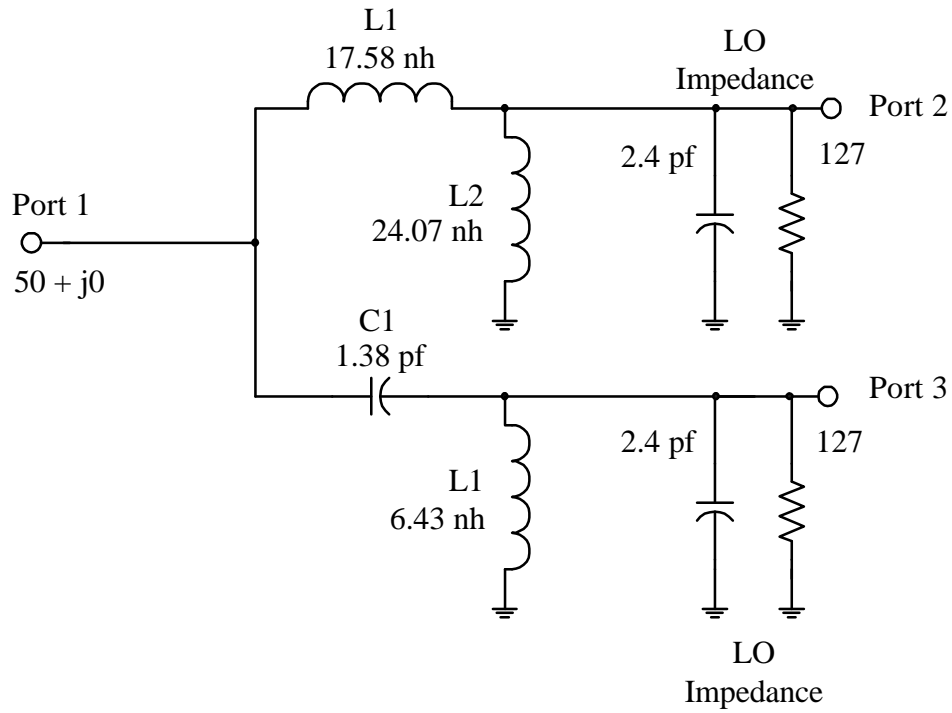
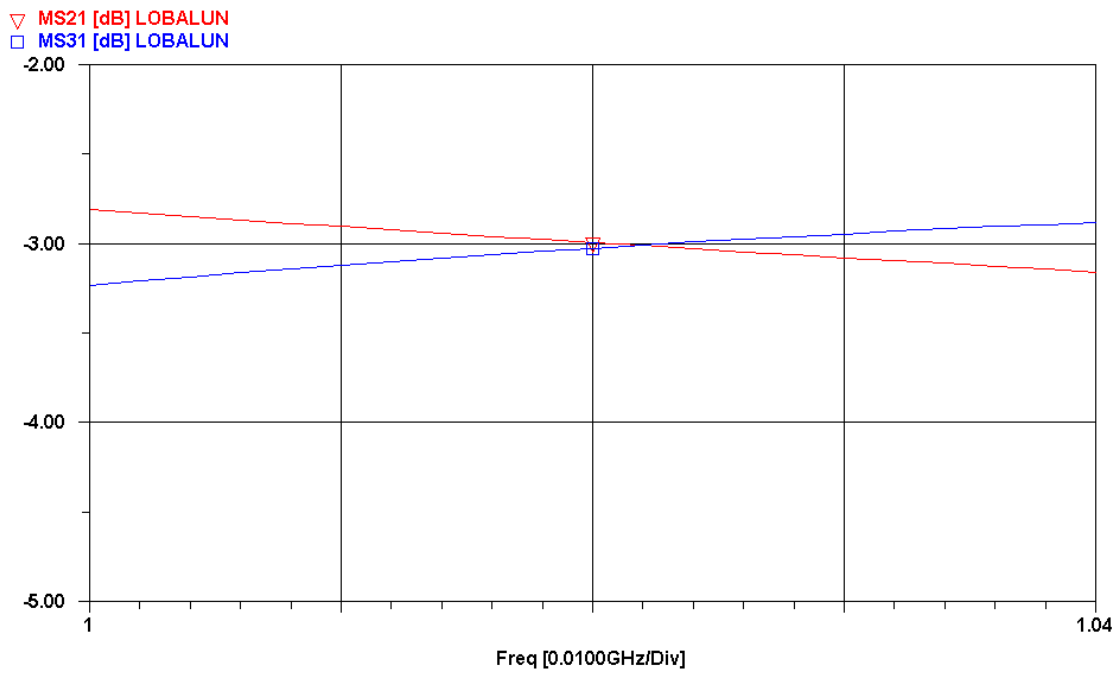

Figure 16

The analysis of the circuit is shown in the following figures.



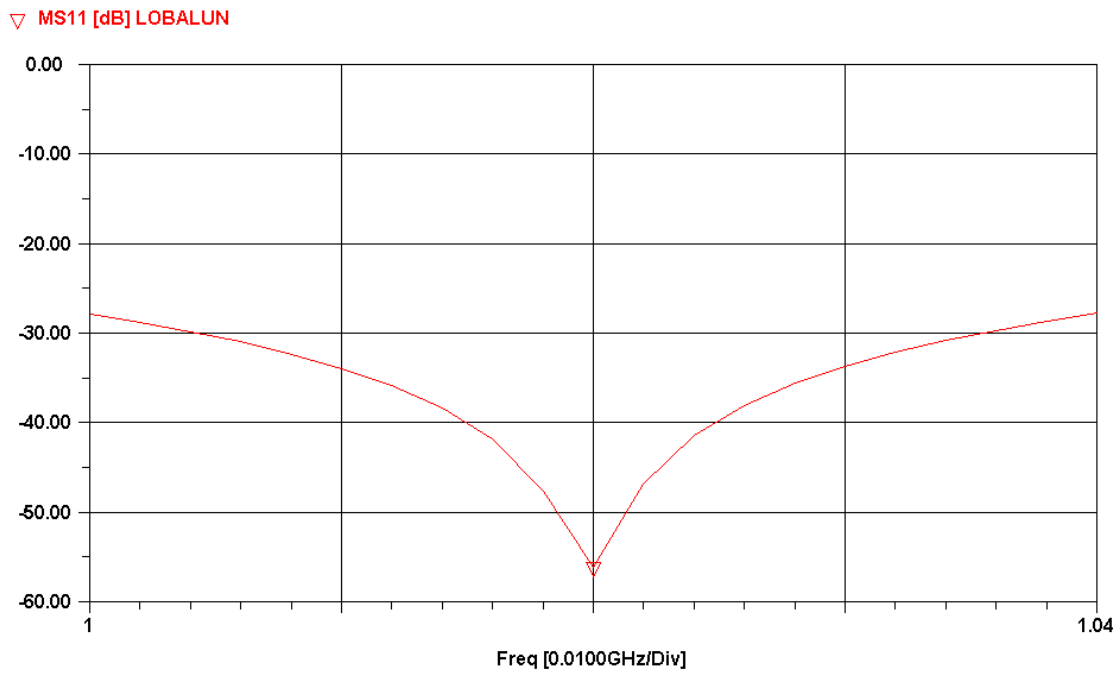
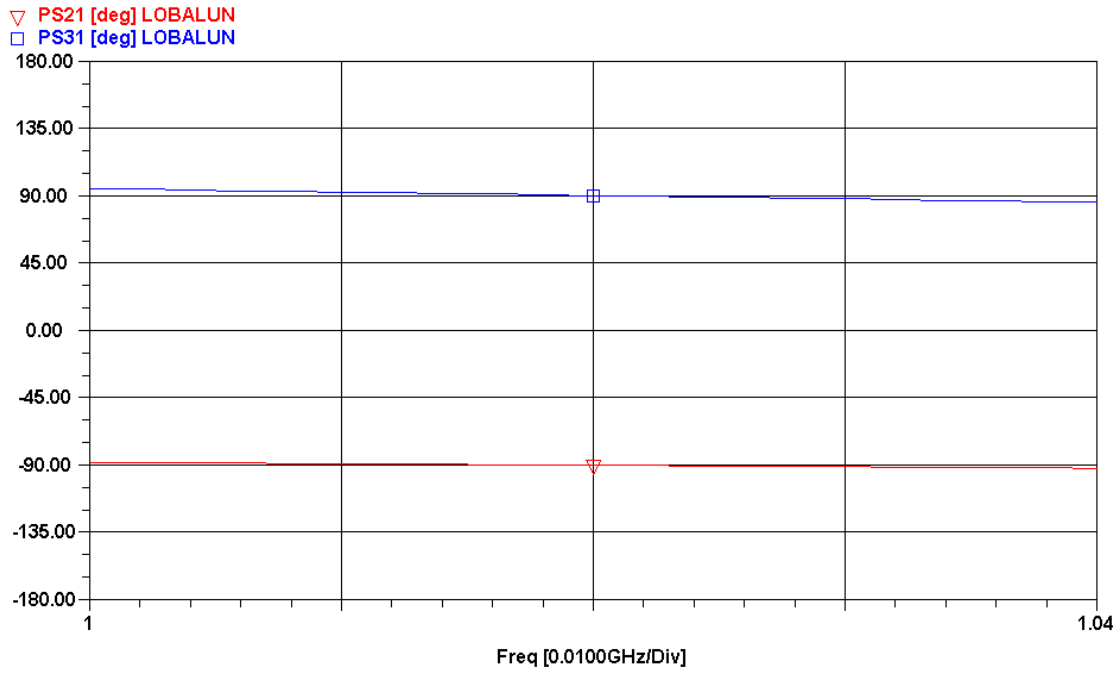

Figure 17

The analysis in Figure 17 shows that a simultaneous impedance match and balun function has been obtained.

RF Port Balun/Matching Network Design

The match to the RF port is designed much the same as the match to the LO port, but the RF port is characterized with s-parameters from a two-port measurement rather than with an equivalent circuit. An equivalent circuit can be determined from the s-parameters by using the method described earlier in this paper. The s-parameters of the RF input are

<u>Parameter</u>	<u>Magnitude</u>	<u>Phase</u>
S ₁₁	0.175	134.5 degrees
S ₂₁	0.412	-10.2
S ₁₂	0.417	-9.7
S ₂₂	0.188	133.2

Using the equations shown earlier for conversion of s-parameters to z-parameters, the calculated z-parameters are found to be

<u>Parameter</u>	<u>Magnitude</u>	<u>Phase</u>
Z ₁₁	52.50	10.39 degrees
Z ₂₁	37.00	2.05
Z ₁₂	37.45	2.55
Z ₂₂	51.95	11.58

The input impedance is given by

$$Z_{in} = z_{11} + z_{22} - (z_{21} + z_{12})$$

$$Z_{in} = 28.1424 + j16.9067$$

$$Z_{in} = 28.1424 \text{ ohms in series with } 2.99 \text{ nh}$$

or

$$38.30 \text{ ohms in parallel with } 11.27 \text{ nh}$$

From this point, the design process is identical to that performed for the LO port network. The calculated values are found to be

High Pass Network

L1 = 7.76 nh
C1 = 4.04 pf
L2 = 1.56 pf

Low Pass Network

C1 = 4.03 pf
L1 = 7.74 nh
C2 = 9.54 pf

The values shown above were calculated for a network Q of 2.28 which produces a differential phase shift across the output ports of 179.3 degrees. Figure 18 shows the circuit implementation with component values. Notice that the parallel resonant branch has been removed.

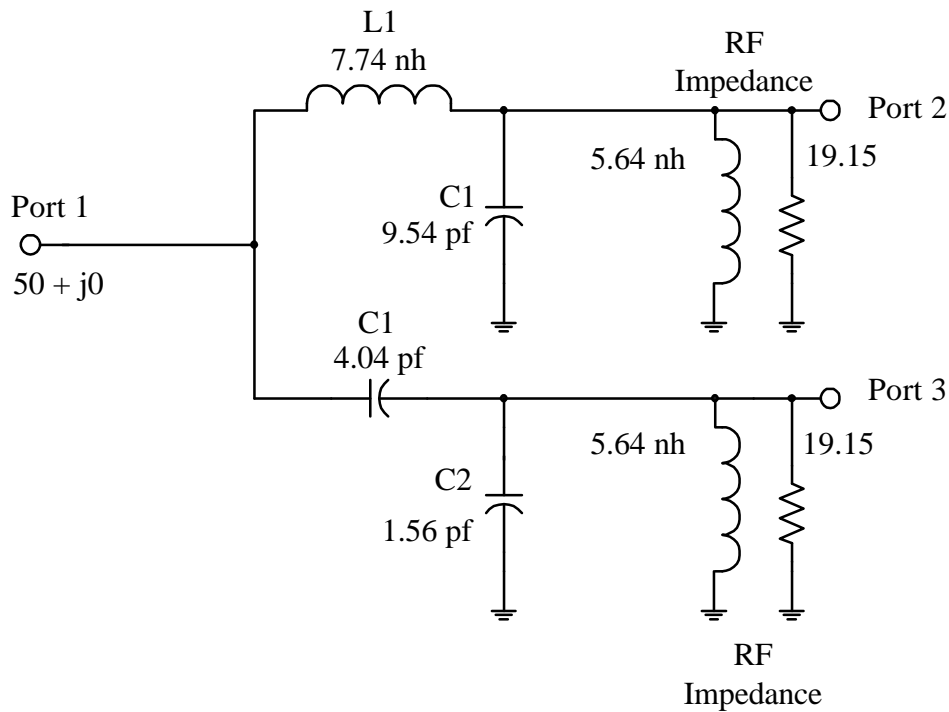
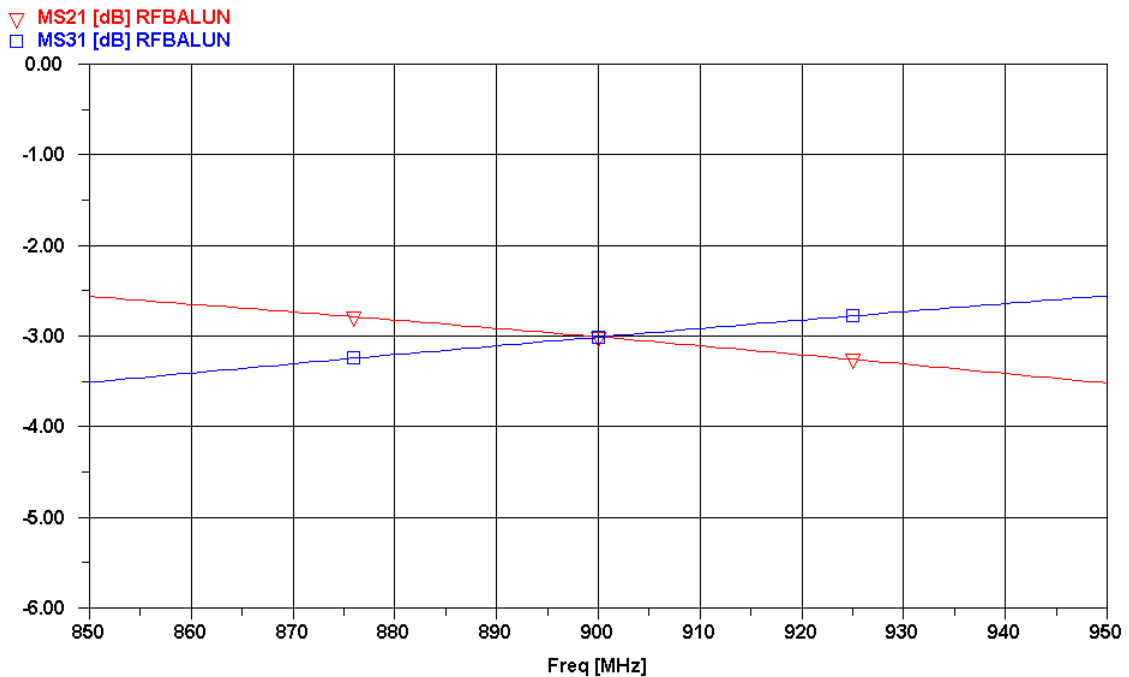

Figure 18

The following plots show the calculated response of the circuit.



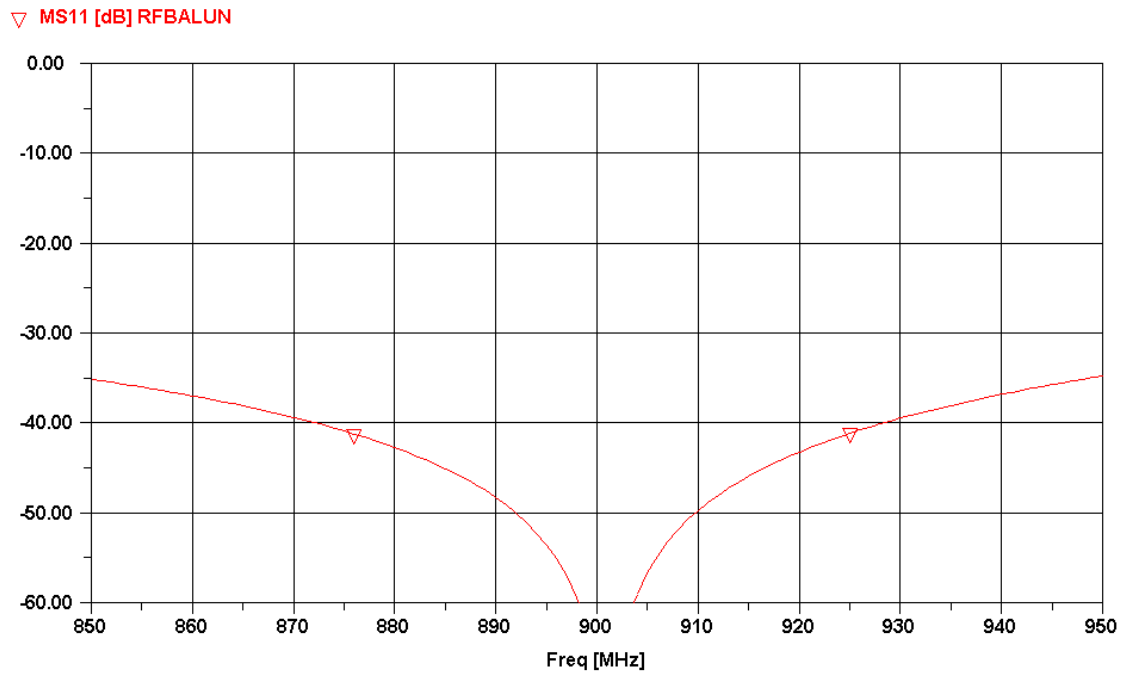
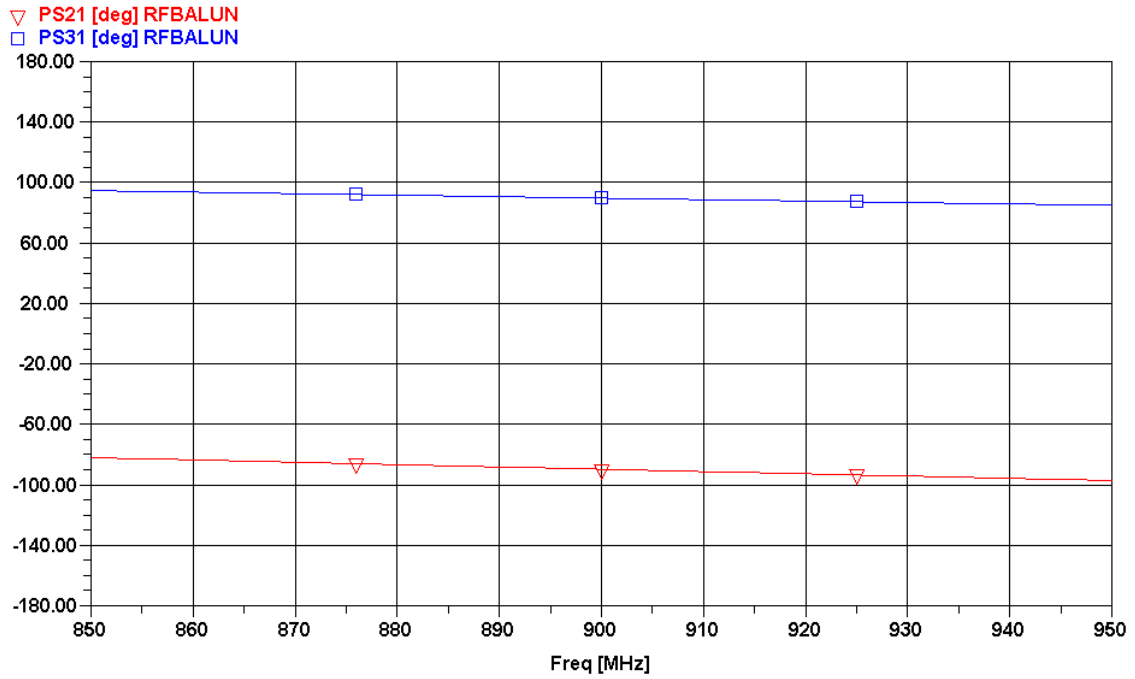
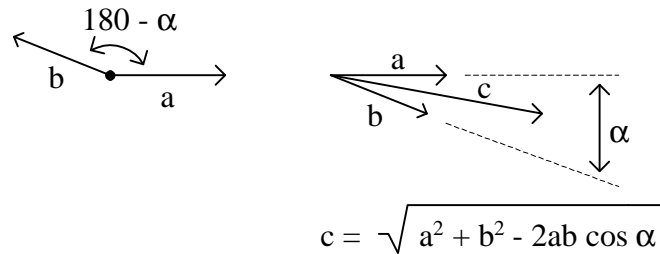
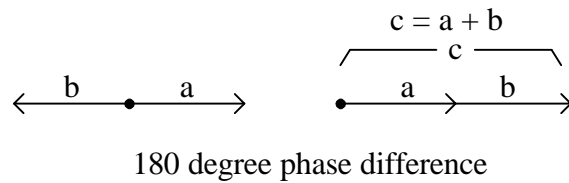

Figure 19

Figure 19 shows that the balun function and impedance match has been achieved at the RF port of the mixer, completing the design.

Accuracy Requirements

The final topic to be considered is how accurate the balance needs to be in terms of magnitude and phase. A differential signal can be viewed as being made up of two vectors, one of magnitude 0.5 at 0 degrees and the second also of magnitude 0.5 at 180 degrees. The output is formed by subtracting the second signal from the first, hence the term differential. In the ideal case, the resultant vector is unity length. Any deviation in the length of the vectors or the angle between them results in a resultant magnitude of less than unity. Figure 20 shows the general relationship between the two vectors.



general case

Figure 20

The loss due to imbalance may be calculated from the above equation using the equal magnitude 180 degree phase difference case as a reference.

Summary

This paper has presented a discussion of the design of balanced to unbalanced conversion and impedance matching networks. A design example was given to make use of the various topics discussed in the paper. With a knowledge of the material in this paper, the RF designer should be able to understand, design, and analyze differential interface circuits.

